

Design and Assessment of Double Axis Solar Tracking System with
Wireless Data Provision by Remote Data Analysis

<http://www.doi.org/10.62341/istj-vol38-2-ra11>

Received	2026/04/05	تم استلام الورقة العلمية في
Accepted	2026/04/26	تم قبول الورقة العلمية في
Published	2026/04/27	تم نشر الورقة العلمية في

Design and Assessment of Double Axis Solar Tracking System with Wireless Data Provision by Remote Data Analysis

Rajab Ali Benalhaj^{1,*}, Haithm Abdallah Shabala¹,
Assadeg Mohamed Akra¹, Alsaid Ali Benalhaj²,
Mohamed A. Gabbasa³

¹Department of Electrical and Electronic Engineering, Zawia Higher
Institute of Science and Technology, Zawia, Libya.

²Department of Production, Mellitah Oil and Gas B.V. Company, Tripoli,
Libya.

³Department of Chemical Engineering, Zawia Higher Institute of Science
and Technology, Zawia, Libya.

Corresponding Author Email: rajabbenahaj@gmail.com

Abstract:

The article has aims to design and assessment an automatic dual axis solar tracking system with provision for remote data analysis, in order to monitor the system. This study uses light dependent resistance LDRs to detect the light intensity of the sun and according to it is signal to the inbuilt ADC of the PIC18F4520 the PIC will give a signal to the motor driver, which will actuate the unipolar stepper motors to move the solar panel into two orientation azimuth and altitude angles. The energy which can be produced by using photovoltaic PV solar cells depends on different factors; an irradiation is one of the most important of these factors. The maximum energy from the sun can be extracted by keeping the solar cells always perpendicular to the incident radiation of the sun. The diurnal and seasonal variation of the earth affects the radiation in the

Design and Assessment of Double Axis Solar Tracking System with
Wireless Data Provision by Remote Data Analysis

<http://www.doi.org/10.62341/istj-vol38-2-ra11>

form of waveform which is received by the solar cells. Solar tracking system moves the solar cells to follow the trajectories of the sun and maintain the orientation of the PV at an optimal tilt angle. By using solar tracking system, the efficiency of the PV can be improved.

Keywords: Double Axis Solar, Tracking System, Wirelessly Data Provision, Remote Data Analysis.

تصميم وتقييم نظام تتبع شمسي ثنائي المحور مع توفير بيانات لاسلكية
عن طريق تحليل البيانات عن بعد

رجب علي بلحاج^{1*} ، هيثم عبد الله شبالة¹ ، الصادق محمد عكره¹ ، السيد علي بلحاج² ،
محمد عبد المجيد قباصة³

¹ قسم الهندسة الكهربائية والالكترونية، المعهد العالي للعلوم والتقنية، الزاوية ، ليبيا

² قسم الإنتاج، الإدارة الفنية، شركة مليتة لإنتاج للنفط والغاز، طرابلس ، ليبيا

³ قسم الهندسة الكيميائية، المعهد العالي للعلوم والتقنية، الزاوية ، ليبيا

المخلص:

تهدف هذه المقالة لتصميم نظاماً آلياً ثنائي المحور لتتبع الشمس، مع إمكانية تحليل البيانات عن بُعد لمراقبة النظام. تستخدم هذه الدراسة مقاومات ضوئية (LDRs) لقياس شدة ضوء الشمس، وبناءً على هذه الإشارة، تُرسل إلى محول تناظري رقمي (ADC) مدمج في وحدة التحكم PIC18F4520. تُرسل وحدة التحكم إشارة إلى مُشغل المحرك، الذي يُشغل بدوره محركات الخطوة أحادية القطب لتحريك اللوحة الشمسية إلى زاويتي سمت وارتفاعهما. تعتمد الطاقة المُنتجة من الخلايا الشمسية الكهروضوئية على عوامل مختلفة، ويُعد الإشعاع الشمسي أحد أهمها. ويُمكن استخلاص أقصى طاقة من الشمس

Design and Assessment of Double Axis Solar Tracking System with
Wireless Data Provision by Remote Data Analysis

<http://www.doi.org/10.62341/istj-vol38-2-ra11>

من خلال الحفاظ على الخلايا الشمسية عمودية دائماً على الإشعاع الشمسي الساقط. يؤثر التغير اليومي والموسمي للأرض على الإشعاع الشمسي الذي تستقبله الخلايا الشمسية على شكل موجة. يُحرك نظام تتبع الشمس الخلايا الشمسية لمتابعة مسار الشمس والحفاظ على اتجاه اللوحة الكهروضوئية بزاوية ميل مثالية. ويمكن تحسين كفاءة الألواح الكهروضوئية باستخدام نظام تتبع شمسي.

الكلمات المفتاحية: نظام شمسي ثنائي المحور، نظام تتبع، نقل البيانات لاسلكياً، تحليل البيانات عن بُعد.

1. INTRODUCTION

The amount of all forms of energy consumed in the world per year is significant increased during the twentieth century reached more than tenfold. More than four fifths of this energy is provided by burns fossil fuels from the total of annual world consumption. 32.4% from the oil, 22.1% from the natural gas and 27.4% from the coal. This increased in the energy consumption is due to the increase in the world population and the uses of the nowadays technology equipment [1]. The fossil fuels are finite recourse of energy; by the rates of currently consumption, it is estimated that the oil will depletion in 45 years, coal in 120 years and natural gas in 60 years. In other hand, the burning of fossil fuels emits a large amount of CO_2 and other toxic gases to the atmosphere. This caused climate change, acid rains and air pollution and has major environmental impact [1,2]. The increase of energy demand worldwide, the fossil fuel limitations and their environmental impact, which is caused by the greenhouse gas emissions and nuclear energy accidents led to research for new energy resources. Solar energy is one of the most important renewable energy sources because of the significant amount of thermal energy which emits from it around the earth in

Design and Assessment of Double Axis Solar Tracking System with
Wireless Data Provision by Remote Data Analysis

<http://www.doi.org/10.62341/istj-vol38-2-ra11>

the form of radiation. Moreover, it is free, clean and can receive its radiation in any place on the earth [1,2].

The solar energy can be used in many different applications. But there are two main applications for it. The thermal heat which depends on heat transfer technology to warm the water which is used for heating purposes, and electricity generation, which depends on the photovoltaic cells (PV) that are used to convert the sunlight intensity direct to electricity without using any moving parts and this generating method does not have any emissions [3]. The electricity which is generated from the sun radiation by using PV depends on the PV cells' efficiency and the amount of intensity of sunlight which can be captured. This efficiency improvement depends on the material and the manufacturing method which has been used, whereas the intensity amount receives depends on the orientation of the PV cells to the sun. There are two types of solar tracking system which are used to keep the PV panel facing the sun's rays. The first one is the single axis solar tracking system. This type tracks the movement of the sun from East to West throughout the day. The second one is the dual axis solar tracking system. This type automatically follows the sun's movement during the days and during the seasons [3,4]. Photovoltaic solar cells are converted solar energy into electrical energy directly without any moving parts and have no any environmental impact. This makes it the most important method to generate electricity from the sun which is an unlimited source of energy [5]. To understand and analyses the solar cell behavior, it is useful to model it by creating an electrical circuit equivalent to it. A current source can be used to model the behavior of the ideal solar cell which is represents the current of the photo generated I_L connected a diode parallel with the current source to represent the solar cell p-n junction. In the ideal solar cell, there is another effect in it is behavior which are the losses in the semiconductor which can be represented by connected resistance in

Design and Assessment of Double Axis Solar Tracking System with
Wireless Data Provision by Remote Data Analysis

<http://www.doi.org/10.62341/istj-vol38-2-ra11>

series R_s with the source in order to cause drop of voltage between the terminal voltage and the voltage of the junction. The other factor is the leaks of the current which are proportional to the solar cell terminal voltage and it can be characterized by connecting resistance parallel with the source of the current R_p . [4,5]. The voltage and the current curve show the main characteristic of the solar cell. It describes the efficiency and the ability of energy conversion of the solar cell. This curve can be used to determine the efficiency and the performance of the solar cell, as showed in figure 1. [4,5].

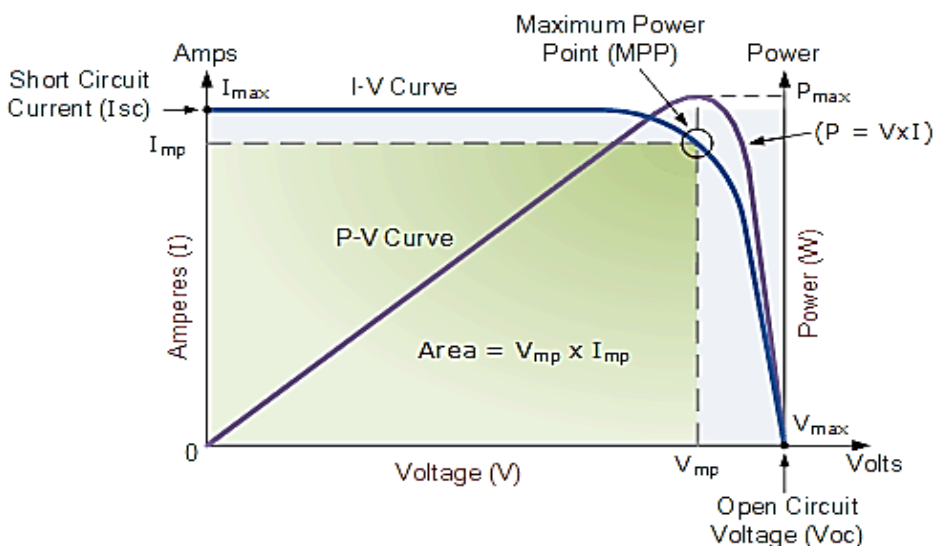

Figure 1. (I-V) Curve characteristic of solar cell.

The graph shows that when the solar cell is not connected to any load, the voltage will be at the maximum value across the cell, whereas the current will be at minimum value (zero) and this called open circuit voltage (V_{oc}). On the other hand, when connecting the positive and negative leads together, the current will reach the maximum value and the voltage will be at minimum value which known in this case short circuit current. The most important thing

Design and Assessment of Double Axis Solar Tracking System with
Wireless Data Provision by Remote Data Analysis

<http://www.doi.org/10.62341/istj-vol38-2-ra11>

from this curve is that the maximum power which the solar cell can generate at this point is the ideal operation point for the PV cells [6].

A single solar cell can generate only 0.5V therefore, in order to generate high voltage value, it should connect many solar cells in a series to form PV panel but the solar panel can generate voltage between 12V to 24V. To generate higher voltage the PV a group of PV panels connected in series forming PV array. On the other hand, to increase the current the PV cell is connected in parallel. For the application need high voltage and high current the solar panel can be connected in series to increase the voltage and in parallel to increase the current as shown in the figure 2. [5,6]. In order to increase the voltage and the current the solar panels can be connected in combination of parallel and series connections as showed in figure 2. [6].

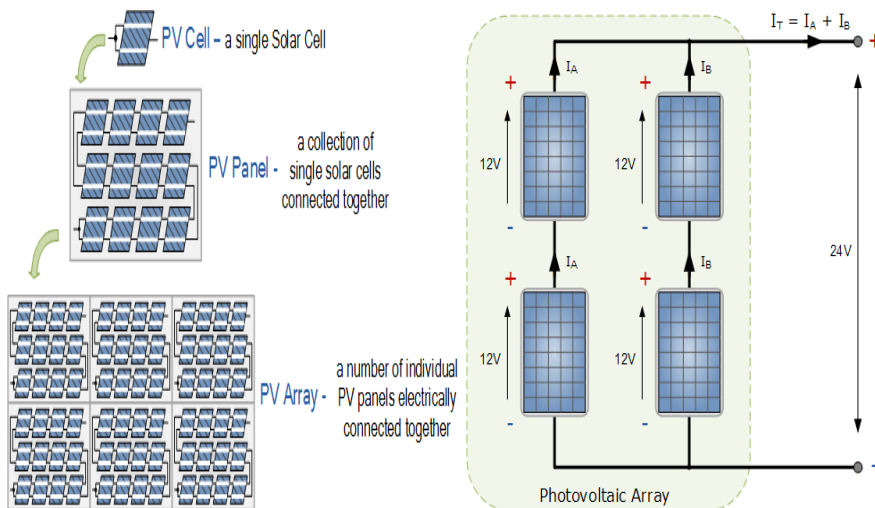

Figure 2. Solar cell module and PV array connection.

The hour angle is the angular distance of the rotation of the earth during a day. It can calculate by multiplies the hours number from

Design and Assessment of Double Axis Solar Tracking System with
Wireless Data Provision by Remote Data Analysis

<http://www.doi.org/10.62341/istj-vol38-2-ra11>

local solar noon by 15 degrees. The earth rotates once every 24 hours 360 degree. Thus, the sun is straight overhead in the noon which is means that the angle of solar hour is zero, therefore this angle before noon is negative and its positive afternoon as the figure 3. [7].

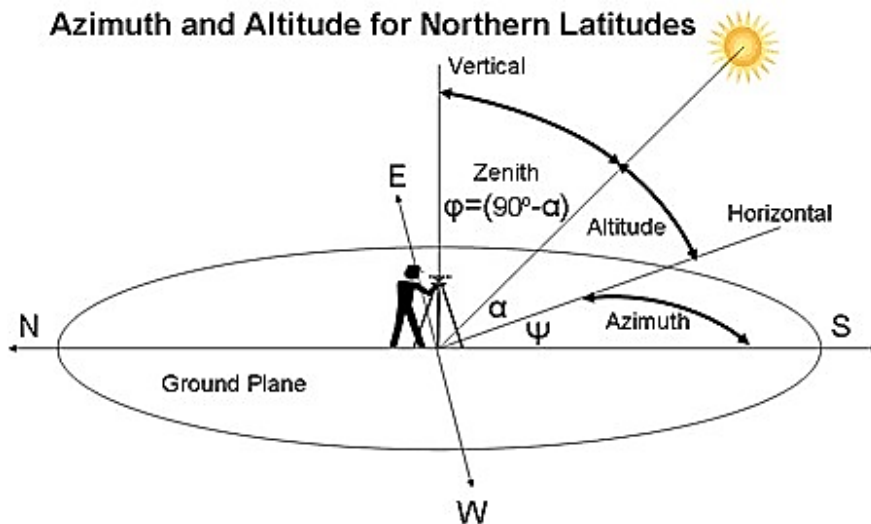

Figure 3. The azimuth and Altitude angles

The solar tracking system that is the amount of energy which can be captured by the photovoltaic solar panel depends on the angle of this PV to the sun arrays and irradiation. That's means the generated power from the PV direct proportional to the angle of it to face the sun arrays. Therefore, to maximize the power production the PV should be always be perpendicular to the sun [8]. To achieve this goal several types of sun tracker are used:

- **Single axis solar tracking system:**

This type of tracker is enabling the PV to tracking the sun from East (sun rise) to West (sun set) throughout the day. This following

Design and Assessment of Double Axis Solar Tracking System with
Wireless Data Provision by Remote Data Analysis

<http://www.doi.org/10.62341/istj-vol38-2-ra11>

rotation of the polar axis which follows the sun during the day is called azimuth.

Increase about 25% in the PV efficiency compared with fixed PV [8].

▪ **Double axis solar tracking system:**

The two-axis tracking system is tracking the sun from East to West (Azimuth angle) and from the North to South (Altitude angle). It increases the PV efficiency to about 45% compared to the fixed PV [9].

This article has aims to design and assessment a dual axis automatic solar tracking system. Four light dependent resistance LDRs have been used as light sensors to detect the sun movement and gives signals to the brain of this circuit, which is the microcontroller PIC18F4520 through it is inbuilt ADC. According to these signals the PIC will give a signal to the motor driver which will actuate the two unipolar stepper motors, one for azimuth angle and the other for the altitude angle. Moreover, this circuit interfacing voltmeter with the PIC will measure the solar panel voltage and send it as serial asynchronous data wirelessly by using GSM module.

2. MATERIAL AND METHODS

The PIC18F4520 Microcontroller is Microchip Technology Inc has manufactured many different types of microcontrollers. The PIC18F4520 is one of the famous families of these PICs with high performance and offer memory with a large size (32K) and provides a range of peripheral devices on it [10]. It has five ports which support different functions which can be used for different applications as in figure 4 below shows the configuration of these ports and the function of each pin.

Design and Assessment of Double Axis Solar Tracking System with
Wireless Data Provision by Remote Data Analysis

<http://www.doi.org/10.62341/istj-vol38-2-ra11>

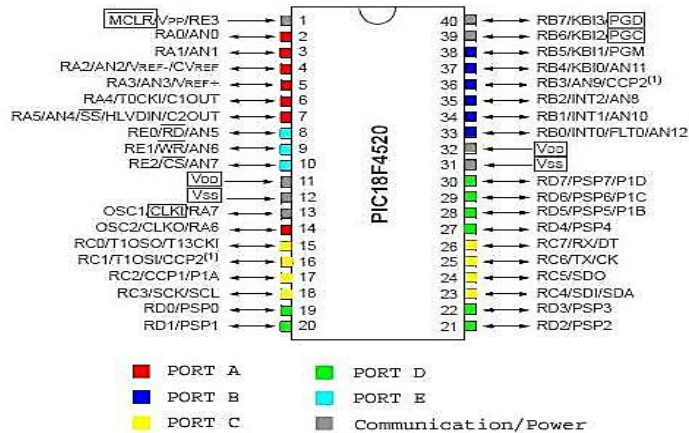

Figure 4. PIC18F4520 Microcontroller

This work has been used some of these features such as the ADC, USART and I2C functions. Therefore, the analog to digital converter (ADC); the PIC18F4520 microcontroller has built-in 10 bits ADC with resolution 1024 and 13 channel can be used as analog input. The conversion time required to complete the conversion is determined by the clock of the microcontroller and the voltage reference which uses as reference of the ADC conversion depends on the ADC resolution [11,12]. The figure 5 below shows the block diagram of the ADC.

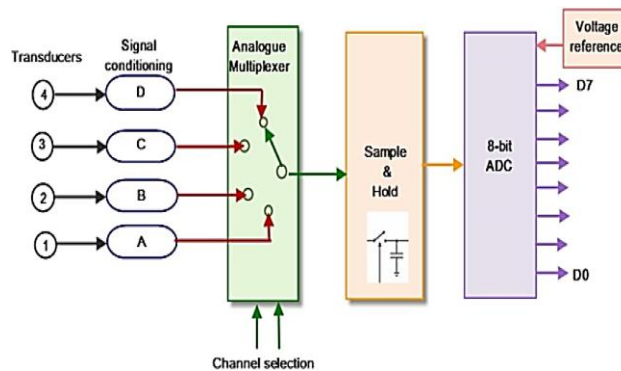

Figure 5. The ADC Block Diagram

Design and Assessment of Double Axis Solar Tracking System with
Wireless Data Provision by Remote Data Analysis

<http://www.doi.org/10.62341/istj-vol38-2-ra11>

Five ADC channels have been used as analogue input from the sensors in this study. The Universal synchronous and asynchronous receiver and transmitter (USART) is used for serial communication between the devices. The PIC18F4520 supports synchronous and asynchronous communication protocols [13]. The transmitter and the receiver have not common clock signal between them therefore sending start bit which always logic low, this bit indicates that new data bits are to be transmitted to the receiver. The transmission data ends by sending stop bits to indicates to the receiver that the data transmission is completed.

The USART can be configured to transmit or receive or both transmit and receive. The figure 6 below shows the transmission block diagram which shows the different registers. Eight or nine bit can be configured to transmit data. This can be achieved by setting the TX9D bit in the TXSAT register, the nine bit must be putted in the TX9D bit of the TXSTA if nine bits are needed before writing the other eight bits in the TXREG register. After the data which to be transmitted is written in the register TXREG, these bits are moved into the transmit shift register and then clocked out on the TX pin by sending the start bit at the first and the stop bit at the end [14].

The stepper motor is an electromechanical device which converts digital pulses in it is winding into mechanical rotation of it is shaft by the electromagnetic effects. It is shaft or spindle rotates in discrete increments steps by applying electrical commend pulses to it is winding with proper sequence [15]. The unipolar stepper motor consists of two windings in each phase and one winding for each magnetic field direction. By switching the winding, the magnetic pole can be easily reversed; this process can be achieved by using a microcontroller or a stepper motor driver which can provide the correct switching sequence for the winding. The unipolar stepper motors have center tap connection which gives six points of

Design and Assessment of Double Axis Solar Tracking System with
Wireless Data Provision by Remote Data Analysis

<http://www.doi.org/10.62341/istj-vol38-2-ra11>

connection, these center taps always connected to the positive power supply rail and the winding energized by the control devices by provide a negative connection as in figure 7.

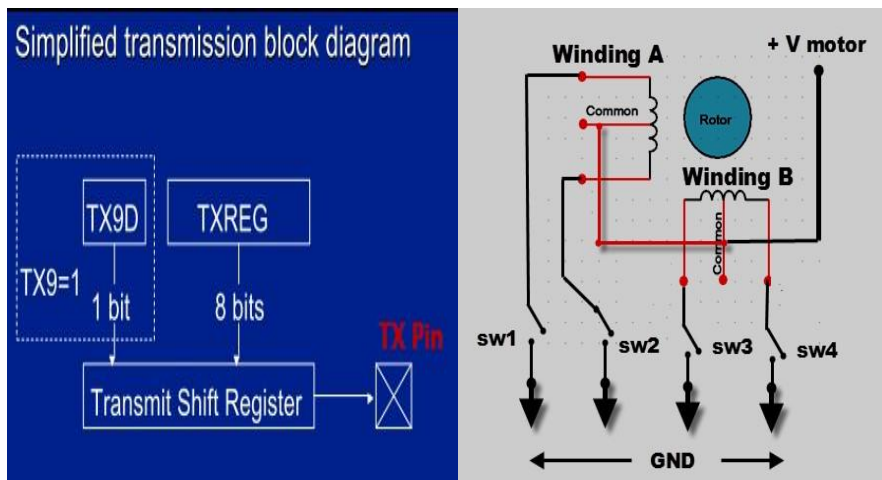

Figure 6. Transmission block diagram. Figure 7. Unipolar step motor operation.

3. BASIC THEORY AND THE PROCESS DESIGN

The first step is the basic theory and the design equations which are used in this circuit design [16].

The second step is the software of the work and the third step is the hardware of the work.

3.1. Light Dependent Resistance (LDR)

This solar tracking system uses four LDRs to detect the light intensity, two of them are used to control the movement of the PV solar panel from East to West (azimuth angle) by using the stepper motor 1 and the other two are to control the movement of the PV solar panel from North to South (altitude angle) by using the stepper motor 2 [17]. Their resistance decreases when the light intensity increased and via versa, therefore to detect the light intensity voltage divider has been used.

Design and Assessment of Double Axis Solar Tracking System with
Wireless Data Provision by Remote Data Analysis

<http://www.doi.org/10.62341/istj-vol38-2-ra11>

By connecting the LDR with DC power supply and connecting a standard resistance in series. This will produce different voltage values proportional to the light levels (voltage divider), this voltage can be determined by using the following equation [18]:

$$V_{out} = \frac{R_{bottom}}{R_{bottom} + R_{top}} * V_{cc}$$

Where: V_{out} is the output voltage, R_{bottom} is the reference resistance, R_{top} is the LDR resistance and V_{cc} is the input voltage.

3.2. Analog to Digital Converter (ADC)

PIC18F4520 has 10bit ADC with 13 built-in analog to digital convertor channels which can be used to interface any analog value to the PIC [19]. In this project the ADC is used to read the data from the LDRs and the voltameter voltage divider according to the voltage supply of these sensors, which can be obtained by the following equation.

For an n-bit ADC, the range voltage from 0 to V_{ref} is divide into $2^n - 1$ intervals as the following equation.

The quantization of the 10bit ADC is:

$$q = \frac{V_{ref}}{2^n - 1} = \frac{5}{2^{10} - 1} = 4.88mV$$

Where: q is the quantization, V_{ref} is the reference voltage and n the number of bits, therefore the minimum voltage which the 10bit ADC can resolve is 4.88mV.

The resolution of 10bit ADC is:

Design and Assessment of Double Axis Solar Tracking System with
Wireless Data Provision by Remote Data Analysis

<http://www.doi.org/10.62341/istj-vol38-2-ra11>

$$\text{Resolution} = \frac{1}{2^n - 1} * 100\% = \frac{1}{2^{10} - 1} = 0.098\%$$

Where: V_{ref} is the same of the supply voltage of the PIC and the V_{in} is any input voltage to the ADC from the sensors (LDRs) which from 0 to 5V . suppose the input voltage is 5V, therefore the ADC reading will be:

$$\text{ADC Reading} = \frac{5}{5} * (2^{10} - 1) = 1023$$

3.3. Solar panel output voltage

The PIC through ADC to be able to read the output voltage of the solar panel which 20V as per its specification voltmeter is needed; Therefore, this can be achieved by simple circuit of the voltage divider [20].

$$V_{out} = \frac{R_2}{R_2 + R_1} * V_s$$

From the ADC calculations above, after reading the value of the ADC, it should do same calculation to change the reading value to volt format as following:

$$\text{ADC Reading} = \left(\frac{X_{value} * 5 * 100}{1023} \right) / 10$$

3.4. USART Baud Rate

To make asynchronous communication between two the PIC18F4520 and GSM modem must be both of them have the same baud rate and due to the GSM working in 9600 baud rates as per its data sheet, therefore the baud rate of the micro should be set to this baud rate [21], it can be achieved by using the following calculation:

$$SPBRG = \frac{Fosc}{(16 * \text{Baud rate})} - 1$$

PIC18F4520 crystal =20 MHZ.

3.5. Stepper Motor

From the stepper motor data sheet, the step angle 7.5° therefore it can be calculating the steps per revolution as following:

$$\text{Step per revolution} = \frac{360^\circ}{\text{step angle}} = \frac{360^\circ}{7.5^\circ} = 48 \text{ Step}$$

The teeth ratio =1:48.

3.6. Software Design

The software section has different aspects to achieve its objectives. The MCC18 protocols and functions such as USART, I2C and ADC have been used. In order to make it simple and to succeeded, the software design has been divided into four parts according to their functions, which are interfacing the LDRs and driven the stepper motors, reading the solar panel output voltage, sending the data wirelessly by using GSM module and interfacing the real time clock. The embedded code of interface LDRs and driven stepper motors pass through many stages and steps such as the header files, variables declaration, ADC function and the motor function [22,23]. The solar panel output voltage is the second part of the main code and in order to read the output voltage of the solar panel though the ADC, voltage divider has been designed as shown in the calculation.

3.7. Hardware Design

The hardware section shows the hardware design and connections of the work and explains how the design works. For the simplicity of the connection and the testing of the design circuit, the hardware divided into three main parts which are interfacing the LDRs and

Design and Assessment of Double Axis Solar Tracking System with
Wireless Data Provision by Remote Data Analysis

<http://www.doi.org/10.62341/istj-vol38-2-ra11>

driven the stepper motors, interfacing the voltmeter and GSM and interfacing the real time clock [22,23].

4. RESULT AND DISCUSSION

The results section demonstrates all the testing of the circuit which has been done and all the results which has been get.

4.1. Solar panel output voltage

The solar panel output voltage has been measured in different weather condition and with different solar panel angles with the sun, to understand the effect of the weather and the solar panel angles in the power output which is produced by the PV.

4.1.1. Cloudy day

On 15th of September 2025 at 15:00 PM some reading of the solar panel has been taken near by the EC building at latitude and longitude which mentioned above. The measurements between the PV open circuit voltage and the PV angle to Sun. Table 1 below shows this reading.

Table 1. Solar panel open voltage with angle reading

Solar panel Angle(Degree)	0	15	30	45	60	75	90
Solar Panel Voltage(V)	13.1	13.34	13.61	13.68	13.76	13.8	13.88
Solar panel Angle(Degree)	105	120	135	150	165	180	
Solar Panel Voltage(V)	13.8	13.76	13.61	13.34	13.26	13.1	

The table above shows that the maximum open voltage output is when the solar panel at 90° angle with the sun rays. This reading a plotted on the curve to give clear picture to the relationship between the output voltages the angle as Figure 8 shows.

Design and Assessment of Double Axis Solar Tracking System with
Wireless Data Provision by Remote Data Analysis

<http://www.doi.org/10.62341/istj-vol38-2-ra11>

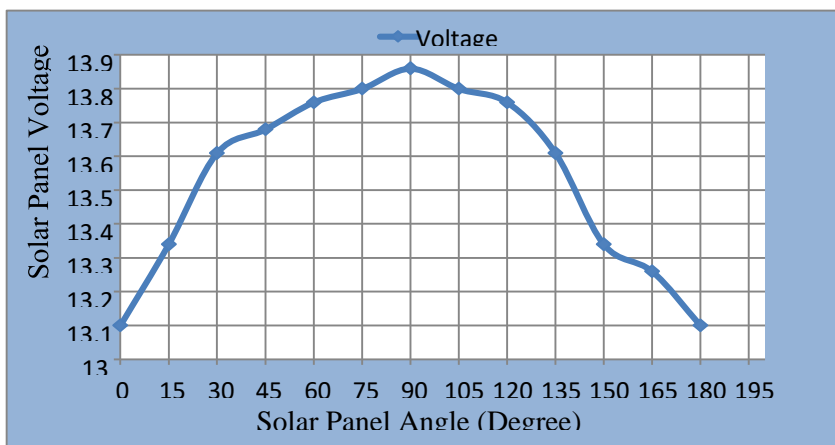

Figure 8. Solar Panel open circuit voltage with the angle

In the same day another reading has been taken of the PV with small load (47Ω) in order to measure the short circuit voltage and current, Table 2 below shows.

Table 2. Solar panel short circuit output voltage and ampere with the angle

Solar panel Angle(Degree)	0	15	30	45	60	75	90
Solar Panel Voltage (V)	1.5	1.8	2.0	2.2	2.4	2.6	2.8
Solar Panel Ampere (A)	0.027	0.032	0.036	0.040	0.047	0.052	0.058
Solar panel Angle(Degree)	105	120	135	150	165	180	
Solar Panel Voltage (V)	2.6	2.4	2.2	2.0	1.8	1.5	
Solar Panel Ampere (A)	0.052	0.047	0.040	0.036	0.032	0.027	

The table above shows that when connected load to the PV, its voltage declines too much due to this load. Figure 9 below shows the

Design and Assessment of Double Axis Solar Tracking System with
Wireless Data Provision by Remote Data Analysis

<http://www.doi.org/10.62341/istj-vol38-2-ra11>

relationship between the PV angle to the sun and its voltage and current.

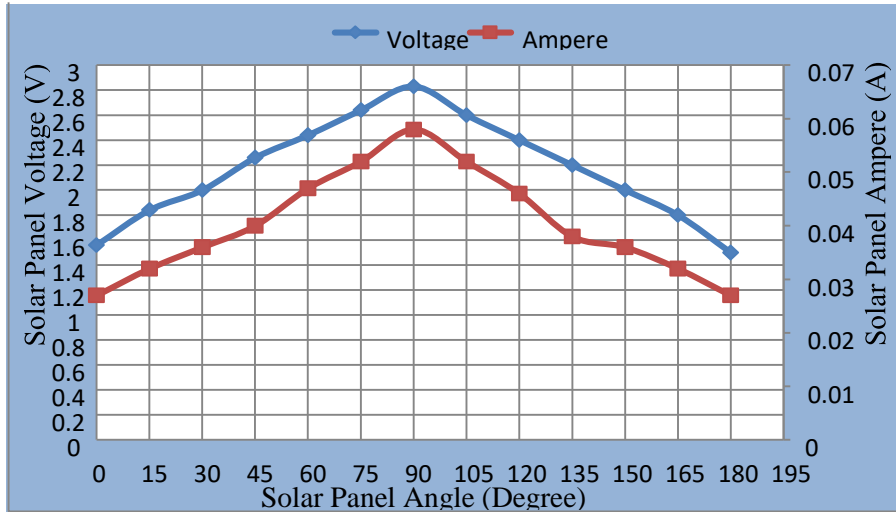

Figure 9. Solar Panel Angle with the Voltage and current

4.1.2. Sunny day

On 22th of September 2025 at 15:00PM another reading of the solar panel output has been taken in the same place which mentioned above. The Table 3. below shows these measurements.

Table 3. Solar Panel open circuit voltage with the angle

Solar panel Angle(Degree)	0	15	30	45	60	75	90
Solar Panel Voltage(V)	16.7	17.1	17.3	17.7	18	18.6	18.9
Solar panel Angle(Degree)	105	120	135	150	165	180	
Solar Panel Voltage(V)	18.7	18	17.7	17.3	17.1	16.7	

As the table above shows that the maximum voltage is when the PV at 90° with the sun rays and the output voltage increased comparing

Design and Assessment of Double Axis Solar Tracking System with
Wireless Data Provision by Remote Data Analysis

<http://www.doi.org/10.62341/istj-vol38-2-ra11>

with the output voltage in cloudy day. The data which is in the table has been a plotted in the figure 10 below.

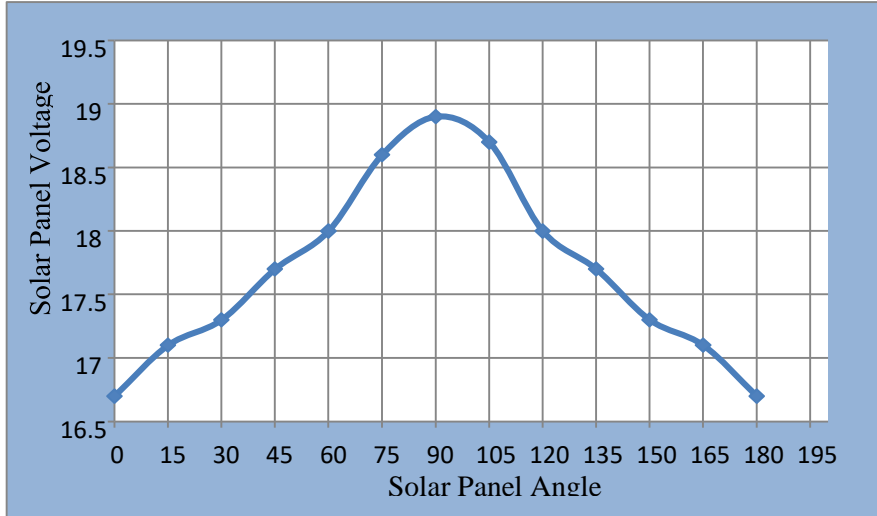

Figure 10. The solar panel open circuit output voltage with the angle. On the same time another measurement has been taken to the PV with load (47Ω) to see the load effect on the voltage output, Table 4 shows.

Table 4. The PV output voltage and current with the angle

Solar panel Angle(Degree)	0	15	30	45	60	75	90
Solar Panel Voltage (V)	4.2	5.2	6.5	7.3	7.5	7.6	7.8
Solar Panel Ampere (A)	0.16	0.22	0.26	0.28	0.30	0.32	0.35
Solar panel Angle(Degree)	105	120	135	150	165	180	
Solar Panel Voltage (V)	7.6	7.5	7.3	6.5	5.2	4.2	
Solar Panel Ampere (A)	0.32	0.3	0.28	0.26	0.22	0.16	

Design and Assessment of Double Axis Solar Tracking System with
Wireless Data Provision by Remote Data Analysis

<http://www.doi.org/10.62341/istj-vol38-2-ra11>

Figure 11 below shows this data in the curve which gives clear idea about the relationship between the PV output voltage and ampere and the PV angle to the sun rays.

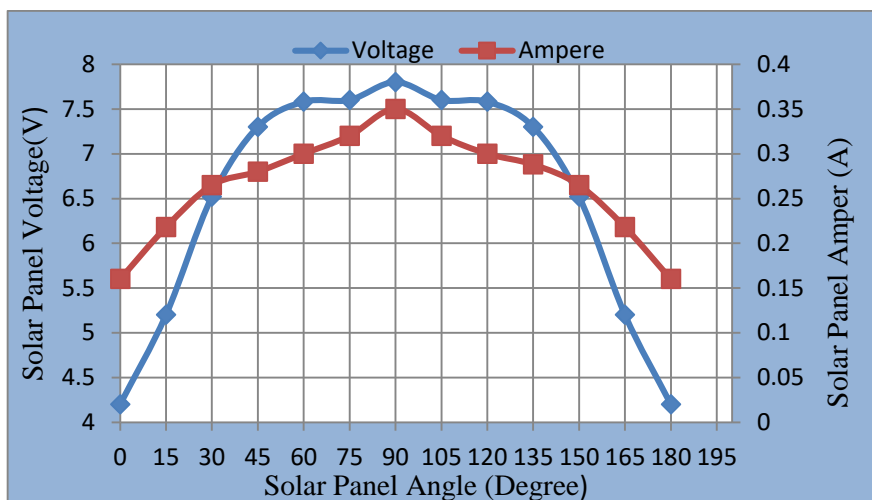

Figure 11. The PV output voltage and current with the angle

It concludes that the efficiency of the solar panel can be increased by keeping the angle between the panel and the sun rays always 90° and this can be achieved by using two axis solar tracking system.

5. CONCLUSIONS

The conclusion will demonstrate the study achievements and the future work recommendations. This work was focused on the design and assessment of a dual axis solar tracking system with wirelessly data provision. Therefore, it can be concluded that the aims and the objectives of this project have been achieved. First the design of the electronic circuit by interfacing the different sensors to the microcontroller has been competed successful in the Proteus software except the interfacing the real time clock and after that implemented by using breadboard and get the expected results

Design and Assessment of Double Axis Solar Tracking System with
Wireless Data Provision by Remote Data Analysis

<http://www.doi.org/10.62341/istj-vol38-2-ra11>

which are the stepper motors rotates according the value of the intensity light on the LDRs. Secondary, reading the output voltage of the solar panel and send it as message through the GSM modem was also completed successfully. Moreover, the PCB design of the circuit was designed by using Ulti board software was completed with some connection mistakes which corrected by using external wire connections. Finally, the article demonstrates solar tracking system design by using different type of sensors, control systems, program languages and actuators. In addition, it can conclude that the dual axis tracking system is more efficient than the single tracking system.

6. RECOMMENDATIONS AND FUTURE WORK

- Solar panel parameters that Instead of reading only the output voltage of the solar panel it is important also to read other parameters of it such as the current and the temperature therefore interfacing ammeter and temperature sensor is recommended.
- GSM modem was used only one GSM which interfaced the microcontroller, for future work is better to use two GSM modem one interfaced with PIC and the other one can be interfaced with hypo terminal as receiver instead of receiving the data in the mobile phone.
- The PIC18F4520 was used but a lot of features of it does not used, therefore another type of microcontrollers which has the functions which needs in the work could be used.

REFERENCES

- [1] E. Kiyak and G. Gol, "A comparison of fuzzy logic and PID controller for a single-axis solar tracking system," Renewables: Wind, Water, and Solar, vol. 3, no. 1, 2016.

Design and Assessment of Double Axis Solar Tracking System with
Wireless Data Provision by Remote Data Analysis

<http://www.doi.org/10.62341/istj-vol38-2-ra11>

- [2] L. A. S. Ferreira, H. J. Loschi, A. A. D. Rodriguez, Y. Iano, and D. A. do Nascimento, "A solar tracking system based on local solar time integrated to photovoltaic systems," *Journal of Solar Energy Engineering*, vol. 140, no. 2, 2018.
- [3] R. Iftikhar, I. Ahmad, M. Arsalan, N. Naz, N. Ali, and H. Armghan, "MPPT for Photovoltaic System Using Nonlinear Controller," *International Journal of Photoenergy*, vol. 2018, Article ID 6979723, 11 pages, 2018.
- [4] M. H. M. Sidek, N. Azis, W. Z. W. Hasan, M. Z. A. Ab Kadir, S. Shafie, and M. A. M. Radzi, "Automated positioning dual-axis solar tracking system with precision elevation and azimuth angle control," *Energy*, vol. 124, pp. 160–170, 2017.
- [5] UNEP, *The emissions gap report 2017: a UN environment synthesis report*, United Nations Environment Programme (UNEP), Nairobi, 2017.
- [6] Jeong, B., Park, J., Kim, S., Kang, J., and Korea, S. (2013). 29, 2013, 414–417.
- [7] S. Oberthür and H. E. Ott, *The Kyoto Protocol International Climate Policy for the 21st Century*, Springer-Verlag, BerlinHeidelberg, New York, USA, 1999.
- [8] N. L. Panwar, V. S. Reddy, K. R. Ranjan, M. M. Seepana, and P. Totlani, "Sustainable development with renewable energy resources: a review," *World Review of Science, Technology and Sustainable Development*, vol. 10, no. 4, p. 163, 2013.
- [9] G. Almonacid, E. Muñoz, F. Baena, P. Pérez-Higueras, J. Terrados, and M. J. Ortega, "Analysis and performance of a two-axis PV tracker in Southern Spain," *Journal of Solar Energy Engineering*, vol. 133, no. 1, 2011. [1]. Khan, T.A., Tanzil, S.M.S., Rahman, R., and Alam, S.M.S. (2010) Design and Construction of an Automatic Solar Tracking System. (December), 18–20.

Design and Assessment of Double Axis Solar Tracking System with
Wireless Data Provision by Remote Data Analysis

<http://www.doi.org/10.62341/istj-vol38-2-ra11>

- [10] IEA, Renewables 2018: analysis and forecast to 2023, International Energy Agency, USA, 2018.[1]. Seme, S. and Stumberger, G. (2011) Maximum Efficiency Trajectories of a Two-Axis Sun. 26 (4), 1280–1290.
- [11] A. Iqbal and M. T. Iqbal, “Design and analysis of a stand-alone PV system for a rural house in Pakistan,” International Journal of Photoenergy, vol. 2019, Article ID 4967148, 8 pages, 2019.
- [12] State, B. and State, P. (2013) DESIGN AND CONSTRUCTION OF AN AUTOMATIC SOLAR. 2 (5), 813–825.
- [13] M. A. Green, K. Emery, Y. Hishikawa, W. Warta, and E. D. Dunlop, “Solar cell efficiency tables,” Progress in Photovoltaics: Research and Applications, vol. 23, no. 1, pp. 1–9, 2015.
- [14] Watane, N.D. and Dafde, R.A. (2013) Automatic Solar Tracker System. 4 (6), 93–100.
- [15] J. A. Duffie and W. A. Beckman, Solar Engineering of Thermal Processes, John Wiley & Sons, 2013.
- [16] A. Wang and Y. Xuan, “A detailed study on loss processes in solar cells,” Energy, vol. 144, pp. 490–500, 2018.
- [17] Zhan, T.-S., Lin, W.-M., Tsai, M.-H., and Wang, G.-S. (2013) “Design and Implementation of the Dual-Axis Solar Tracking System”. 2013 IEEE 37th Annual Computer Software and Applications Conference, 276–277.
- [18] N. Mohammad and T. Karim, “Design and implementation of hybrid automatic solar-tracking system,” Journal of Solar Energy Engineering, vol. 135, no. 1, 2013.
- [19] T. Muneer, C. Gueymard, and H. Kambezidis, Solar Radiation and Daylight Models, Elsevier Ltd, Amsterdam, 2nd edition, 2004.

Design and Assessment of Double Axis Solar Tracking System with
Wireless Data Provision by Remote Data Analysis

<http://www.doi.org/10.62341/istj-vol38-2-ra11>

- [20] Amir Abas, M., Hilmi Fadzil S, M., Kadir, S. a., and Khusairy Azim, a. (2010) “Improved Structure of Solar Tracker with Microcontroller Based Control”. Proceedings - 2010 2nd International Conference on Advances in Computing, Control and Telecommunication Technologies. 55–59.
- [21] B. Y. H. Liu and R. C. Jordan, “The interrelationship and characteristic distribution of direct, diffuse and total solar radiation,” Solar Energy, vol. 4, no. 3, pp. 1–19, 1960.
- [22] A. farulrazi, B., Utomo, W. M., Liew, K.L., and Zarafi, M. (2011) “Solar Tracker Robot Using Microcontroller”. 2011 International Conference on Business, Engineering and Industrial Applications. pp.47–50.
- [23] T. Yetayew and T. R. Jyothsna, (2013). “Improved single-diode modelling approach for photovoltaic modules using data-sheet,” in 2013 Annual IEEE India Conference (INDICON), pp. 1–6.